

SYSTEM 3000 / 4000

**FLAME AMPLIFIER MODULE
3001D**

TECHNICAL DESCRIPTION

EDITION TB 3001D-SZ1

Flame amplifier module 3001D

- Precise display of intensity
- Fault diagnosis
- Setting of threshold value
- Variable closing delay time
- Variable OFF delay time
- Relay signal output
- Pre-alarm

Application

The flame scanner **3001** is a system plug-in unit of the **3000** line, which, in connection with the flame detectors of the system, is providing full-scale flame monitoring for any burner output, fuel, and combustion process.

The flame monitoring system **3000/4000** is tested by TÜV in accordance with EN 230 and EN 298 and approved according to DIN DVGW

and DIN CERTCO. It meets the requirements of TRD 411 to 414.

The plug-in unit is approved for continuous operation because of continuous fully electronic fail-safe checking of its function.

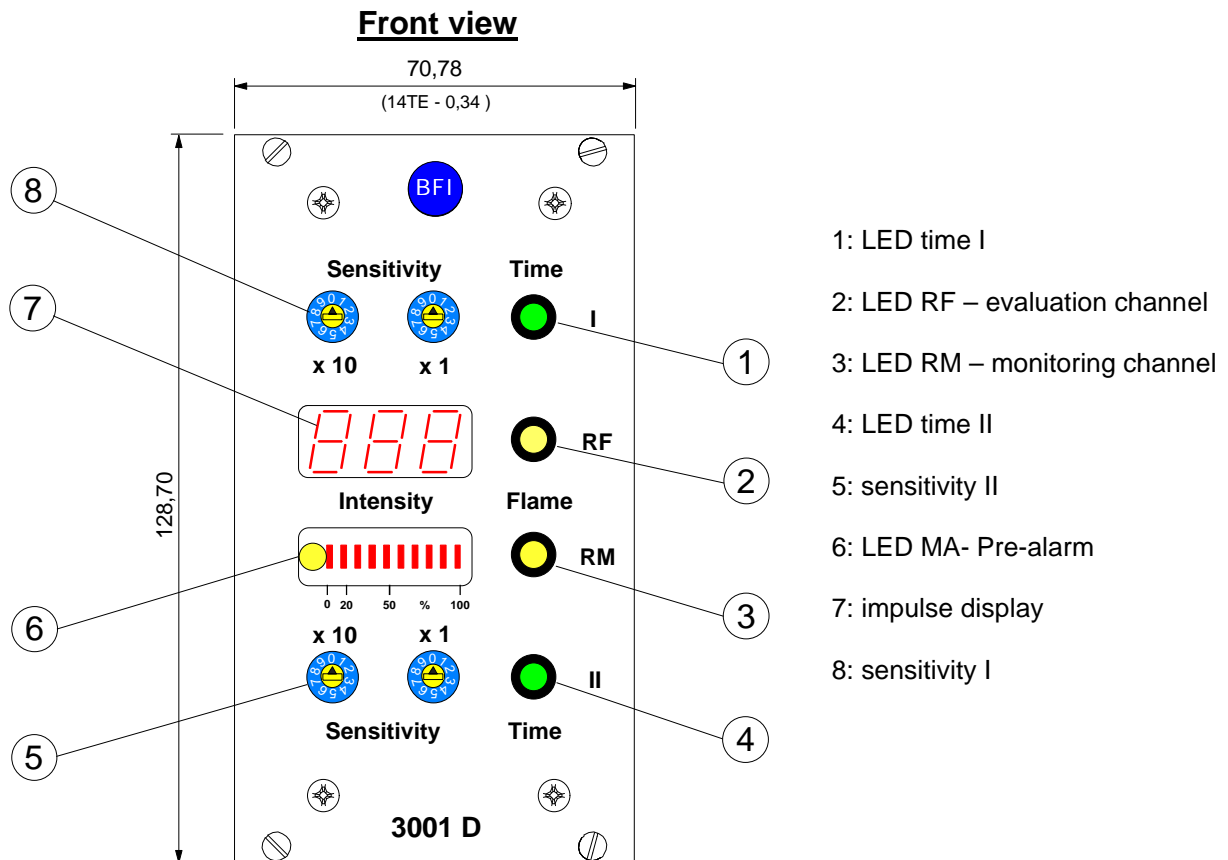

Function

The self-checking and fail-safe flame scanner **3001** contains two separate signal processing channels of differing layout, which are being synchronised by a processor. Internal and external faults of any kind trigger automatically immediate actuation of the safety devices.

Two independent monitoring levels (time level I, time level II) can freely be selected by means of an external control signal. Each level is described by its sensitivity setting and sign-off time. In this way a fuel- and load-related optimisation of flame monitoring is easy to implement. The connection of a second flame detector in parallel or alternating operation is possible.

The output signal of the flame detector is transmitted as a pulse message via a filter and pulse shaper stage to the sensitive controllers. Two rotary switches are available per time level for setting the desired signal amplification. This flame signal is distributed on three further function channels:

1. Measuring channel (M)
2. Monitoring channel (RM)
3. Evaluation channel (RF)

MEASURING CHANNEL (M)

The analog measuring channel is designed as a attenuation filter with signal contractor followed by a voltage-current transformer. The output of the transformer supplies the internal analog intensity indicator and through output terminals the remote display instruments with 0 - 20 mA resp. 4 - 20 mA.

The digital measuring channel controls the 3-digit 7-segment indication and provides the number of flame scanner pulses immediately upon recognition of flame. The indicated digital value corresponds to the intensity of flame during the combustion process within the monitored flame section and is independent from the chosen flame amplifier sensitivity.

The following parameters generally define the number of pulses:

Flame scanner alignment
 Type of fuel
 Combustion speed
 Air-/fuel rate
 Flue gas recirculation
 Flame temperature

MONITORING CHANNEL (RM)

The monitoring channel contains all the periodical self-monitoring checks of the system required for continuous operation. In case of malfunction of the flame monitoring system **3000** the processor-based control logic reacts immediately and the relay assigned to LED RM drops and interrupts burner operation within the safety switch off time set for the monitoring channel (S4/S5). Should the LED RM not be lit during burner start operation or extinguish during operation the following malfunctions may exist:

- a) Module defect in flame scanner **3001** for inst. failure of clock signal.
- b) Disturbing pulse effects on not correctly connected or installed flame detector lines (induced voltage).
- c) Defects in the electronic system of the flame detector.

EVALUATION CHANNEL (RF)

The evaluation channel contains all the necessary precision components which are providing the sign-off times differing per level. The sign-off times are selected per DIP switches (S2/S3). Further, the evaluation channel supports the setting of the hysteresis for pre-selecting the switching threshold "Flame on" (DIP switch S1). In connection with the monitoring channel the evaluation channel addresses the output relay K 101.

After satisfactory start-up of the monitoring system **3000** the LED RM lights up immediately at flame signal, whereas the LED RF switches time-delayed depending on selected sensitivity and hysteresis stage. The important floating relay contact K 101 "Flame on", assigned to the external safety circuit, is fused inside the device, thus excluding any contact welding. In addition, a further non-fused auxiliary circuit is available.

An adjustable pre-alarm (MT) signals, depending on flame intensity, unfavourable combustion processes, prior to definite switching off. Indication is by LED MA. For external processing an output 24V/100 mA is available.

connection diagram 3001D

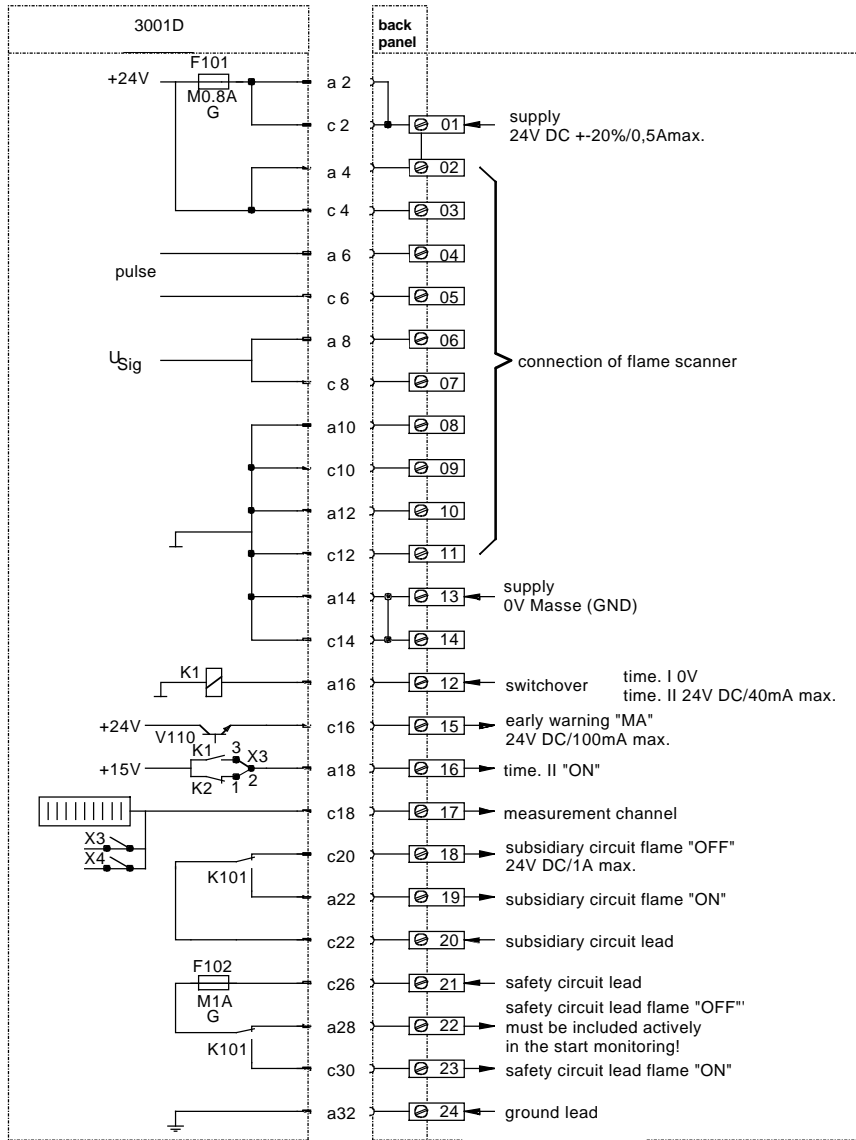

connection diagram flame scanner

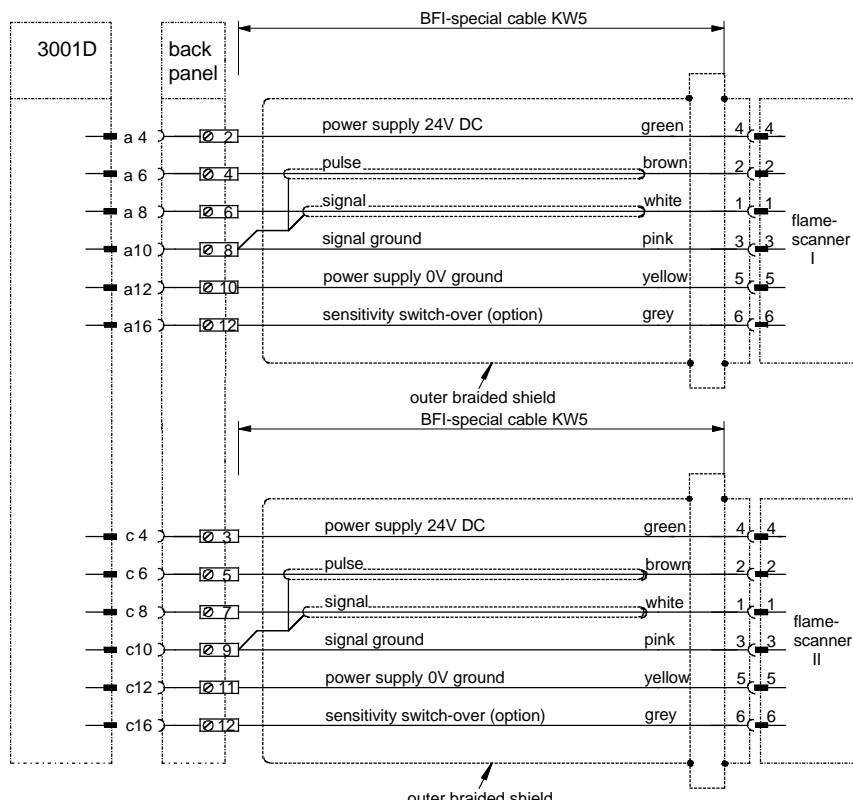

ATTENTION:

The outer braided shield shall be clamped between the plastic insert and the screwed coupler in the compression gland on the scanner side. The inner screening shall be cut on the scanner side and connected to ground at the flame controller.

Technical data

Self-monitoring for the fail-safe function control accordance to EN 230, EN 298. Conforms to the requirement of DIN VDE0116 and TRD 411 to 414, approved accordance to DIN VDGW and DIN CERTCO.

Two safety times	set in 1 - 6 steps (1 –6 seconds), longer times on request
Two sensitivity ranges	set by digital switches, ratio 1 : 99
Hysteresis:	
Switchpoint flame „ON“	adjustable in 64 steps, 5 - 15 mA
Switchpoint flame „OFF“	< 5mA
Flame relay:	2 changeover contacts, floating 1 changeover contact internal fused 1A
Flame intensity display:	0-100% (Built-in luminous bar indicator)
Current output 0-20 or 4-20 mA:	selection-jumper shunt resistance max. 300Ω
Flame evaluation display:	000 – 999 , LED-seven segment
Display range:	1:1, 1:2, 1:4
Pre-alarm :	set by 10 steps/2mA
Pre-alarm output	24 V, 100 mA, short circuit proof
Channel selection:	24 V, 40 mA
Quantization switchover:	plug-in bridges
Locked range switchover or monitoring channel „off“	message 15 V/10 mA
Status indication on LED`s:	channel I or channel II 'on' = green evaluation channel (RF) and monitoring channel (RM) 'on' = yellow Pre-alarm signal (MA) 'on' = yellow
Supply:	24V DC +/-20%, 500mA
Current consumption:	approximate 150mA
Operation temperature:	-20°C to +60°C
Protection:	IP 20
Weight:	700 g
Part-no.:	G 601

The following applies to the safety circuit:

VDE 0110, class C 250 V	
max. switching voltage:	250 V ohmic load
max. switching current:	1 A, ohmic load
max. switching power:	300 VA

All modules of the serie **3000** are plug-in types for using in 19“-magazines accordance to DIN 41494 (19“-norm).

The dimensions of all modules are:

wide	70,9 mm = 14 DIV
high	132.5 mm=3 DIV
deep	188.0 mm

Edition: 07/98, Right of technical modifications reserved.